

A5



Experience sporty
and elegant driving





**Given the front
of this sporty four-door
vehicle its edge**



Single frame with the honeycomb grille.



The classic quattro® blisters fenders make the car appear more powerful and muscular, and the body is lower, flatter and more ground-grasping.

**The new-generation Audi A5 Sportback
is sportier and more attractive than ever**

With the A5 Sportback you stand out from the crowd. The striking design of this four-door coupe gives it depth and width.

Large side air inlets and the wide, deep Singleframe dominate the front of the Audi A5 Sportback.



The Audi A5 Sportback impresses with its striking long tapering roof line, generously spacious feel and everyday usability. Thanks to four-door and large interior, it offers plenty of space in the luggage compartment as well as in the rear.

Fuel consumption combined¹:
5.9 – 5.8 l/100 km;
CO₂ emissions combined¹:
137 – 132 g/km

¹ Fuel consumption CO₂ emission figures given in ranges depend on the tyre/wheel sets used

Amazing design – fantastic to drive.

**Class-leading wheelbase 2,824mm for
outstanding interior space and legroom**

An elegant body line characterises the side view of the Audi A5 Sportback. At the sides, midheavy sills underscore its sportiness and pronounced wheel arches emphasise the optional 20-inch alloy wheels.



Apart from the appealing exterior, the four-door coupé offers impressive driving experience like a sports car. The Audi A5 Sportback impresses with its striking long tapering roof line, generously spacious feel and everyday usability. Thanks to fourdoor and large interior, it offers plenty of space in the luggage compartment as well as in the rear.

Besides, A5 is well equipped to satisfy dynamic driving experience, such as bucket sport seat, the leather multi-function steering wheel, dynamic layout of virtual cockpit with MMI touch screen to ensure a pleasant driving experience and visual enjoyment (see more in the next page).

1	2
3	4
5	6

1. Sports front seats.
2. Spacious interior with panoramic sunroof.
3. Exceptional truck volume up to 1,280L with seats folded.
4. Class-leading legroom.
5. Optional Bang & Olufsen 3D stereo system.
6. Gray Natural Oak inlay.

Variety driving style

The optional dynamic steering in the Audi A5 Sportback adjusts the vehicle's steering ratio and steering power to the vehicle speed, thus delivering irresistible sportiness and enhanced driving comfort directly to the road. Audi drive select and the dynamic, comfort, auto, individual and efficiency modes mean that the driving style can be adjusted at any time.

With the mild-hybrid technology, which can reduce fuel consumption by recovering energy during day-to-day operation.



Everything in focus

The Audi virtual cockpit plus is also available to bring the information most important to the driver into view on a 12.3-inch full HD display. Offering a choice of three layouts, the standard Audi virtual cockpit plus presents the information most important to the driver, with custom operation, intuitive menu navigation and driver-oriented display.



Personal and digital

Control the digital world of the Audi A5 Sportback intuitively with the 10.1-inch MMI touch display or with everyday speech commands.



See what others don't

Audi is pioneering in LED lighting technology. In the new, purist design, the standard Matrix LED headlights with dynamic indicators of the Audi A5 Sportback impress both visually and with their smart, adaptable light.

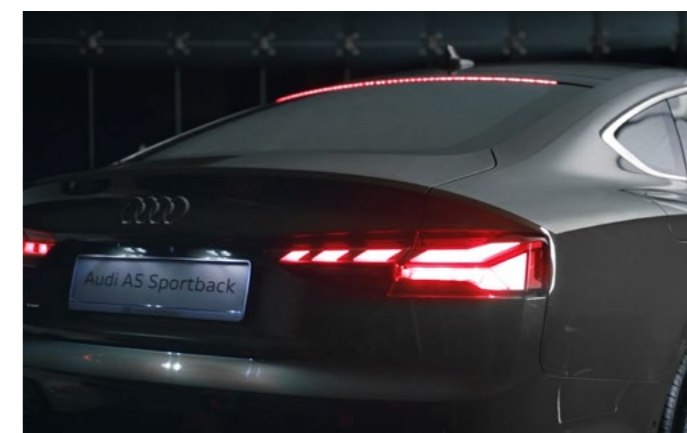

Brightly lit

The LED rear lights dovetail with the horizontal design of the Audi A5 Sportback.



Powerful Presence

With Audi wheels, you can emphasize your own individual style and the character of your Audi A5. Why not indulge yourself and create a powerful presence with your favorite design. For peace of mind on the road: Audi wheels are subjected to special test procedures, undergo rigorous testing and are of superb quality.

18"



19"

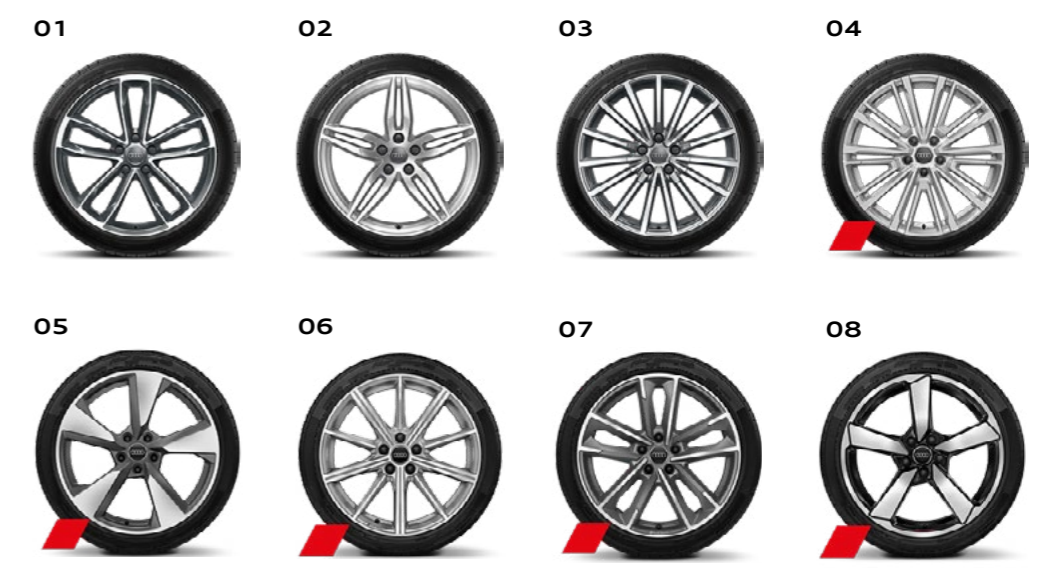

20"



The Audi premium customized paint finishes

You don't get a second chance to make a first impression. Seize this one and choose your own personal exterior paint finish from the wide range of Audi exclusive colours.

Standard



Quantum gray



Turbo blue



Ibis white

Metallic



District green metallic



Glacier white metallic



Mythos black metallic



Navarra blue metallic

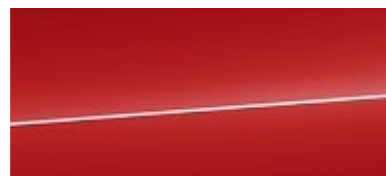

Tango red metallic

Pearl effect



Daytona gray pearl effect

An individual vehicle for your unique personality.

With leather upholstery and trim. You have a special place in your Audi. Exclusive comfort can be felt on the front and rear seats: thanks to high-quality materials and first-class workmanship. Regardless of which seat upholstery you choose, you're sitting in the right place.

Combination equipment



Leather / synthetic leather mono.pur 550 combination

Audi high quality wood upper inlays



Inlays in carbon twill



Audi exclusive black piano lacquer inlays

Model	S line 40 TFSI S tronic
Engine type	In-line 4-cylinder FSI petrol engine, turbocharged, with mild hybrid
Displacement in cc (valves per cylinder)	1984 cm ³
Max. output ² in kW at rpm	190 hp / 4,200 - 6,000 rpm
Max. torque in Nm at rpm	320 Nm / 1,450 - 4,200 rpm
Power transmission	
Drive type	Front wheel drive
Transmission type	7-speed S-tronic
Weights / capacities	
Empty weight	1,590 kg
Perm. Total weight	2,085 kg
Permissible roof load limit / Support load	90/80 kg
Mileage	
Top Speed	241 km /h
Acceleration	0-100 km/h:7.5s
Consumption	
Fuel type	Super sulfur-free 95 RON
Consumption and emission values according to NEDC	
Urban	7.4-7.7 l / 100 km
Extra - urban	4.7-5.1 l / 100 km
Combined	5.9-5.8 l / 100 km
Combined CO2 emissions	137-132 g/km
Emission class	Euro 6d-TEMP-EVAP-ISC

Explanatory note

1. We are currently still required by law to state the NEDC figures. In the case of new vehicles which have been type-approved according to the WLTP, the NEDC figures are derived from the WLTP data. It is possible to specify the WLTP figures voluntarily in addition until such time as this is required by law. In cases where the NEDC figures are specified as value ranges, these do not refer to a particular individual vehicle and do not constitute part of the sales offering. They are intended exclusively as a means of comparison between different vehicle types.
2. Additional equipment and accessories (e. g. add-on parts, different tyre formats, etc.) may change the relevant vehicle parameters, such as weight, rolling resistance and aerodynamics, and, in conjunction with weather and traffic conditions and individual driving style, may affect fuel consumption, electrical power consumption, CO₂ emissions and the performance figures for the vehicle.

Audi A5 Sportback

Dimensions in mm

Dimensions are for empty vehicle weight. Luggage capacity 465 l / 1,280 l

(second value is with the rear seat backrest folded down and the vehicle loaded up to roof height). Turning circle approx. 11.7 m.

* Maximum headroom. ** Elbow room width. *** Shoulder room width. **** Vehicle height with roof aerial.

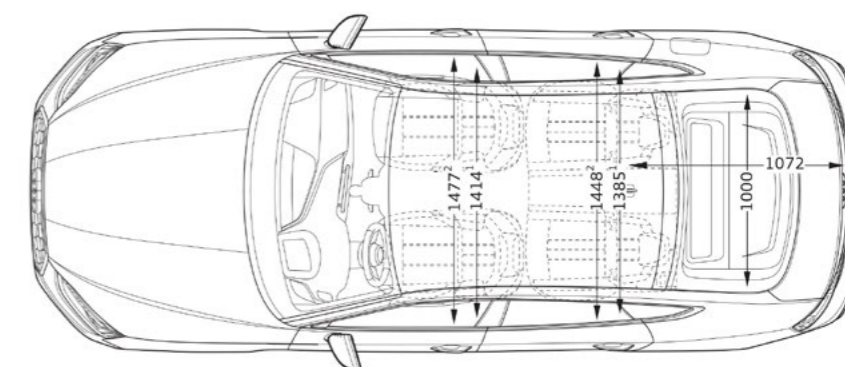
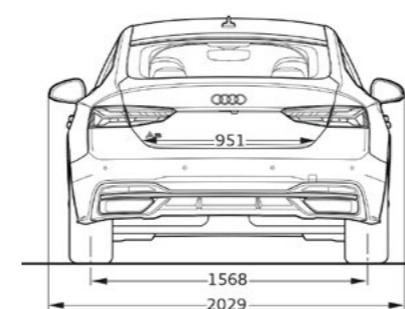
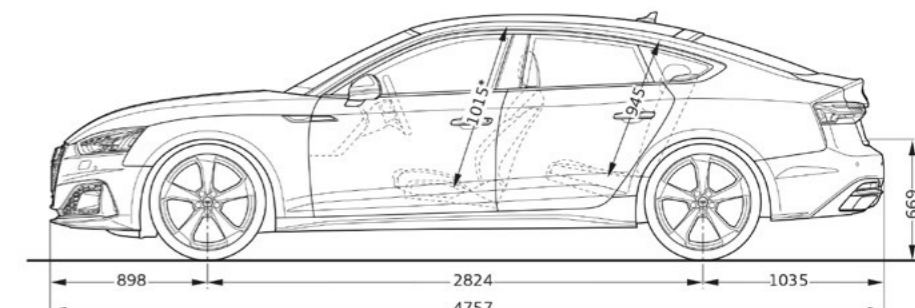
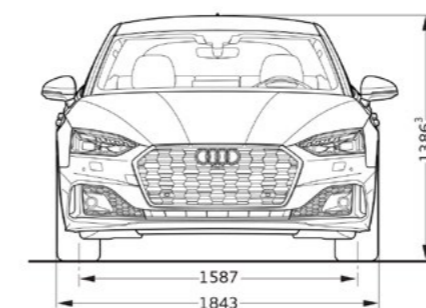



© 2020 Kam Lung Motors Limited. All rights reserved

The equipment, data and prices specified in this document refer to the model range offered in Hong Kong. Subject to change without notice; errors and omissions excepted.

www.audi.com.hk