

# Q4 e-tron

E-mobility in a new dimension.

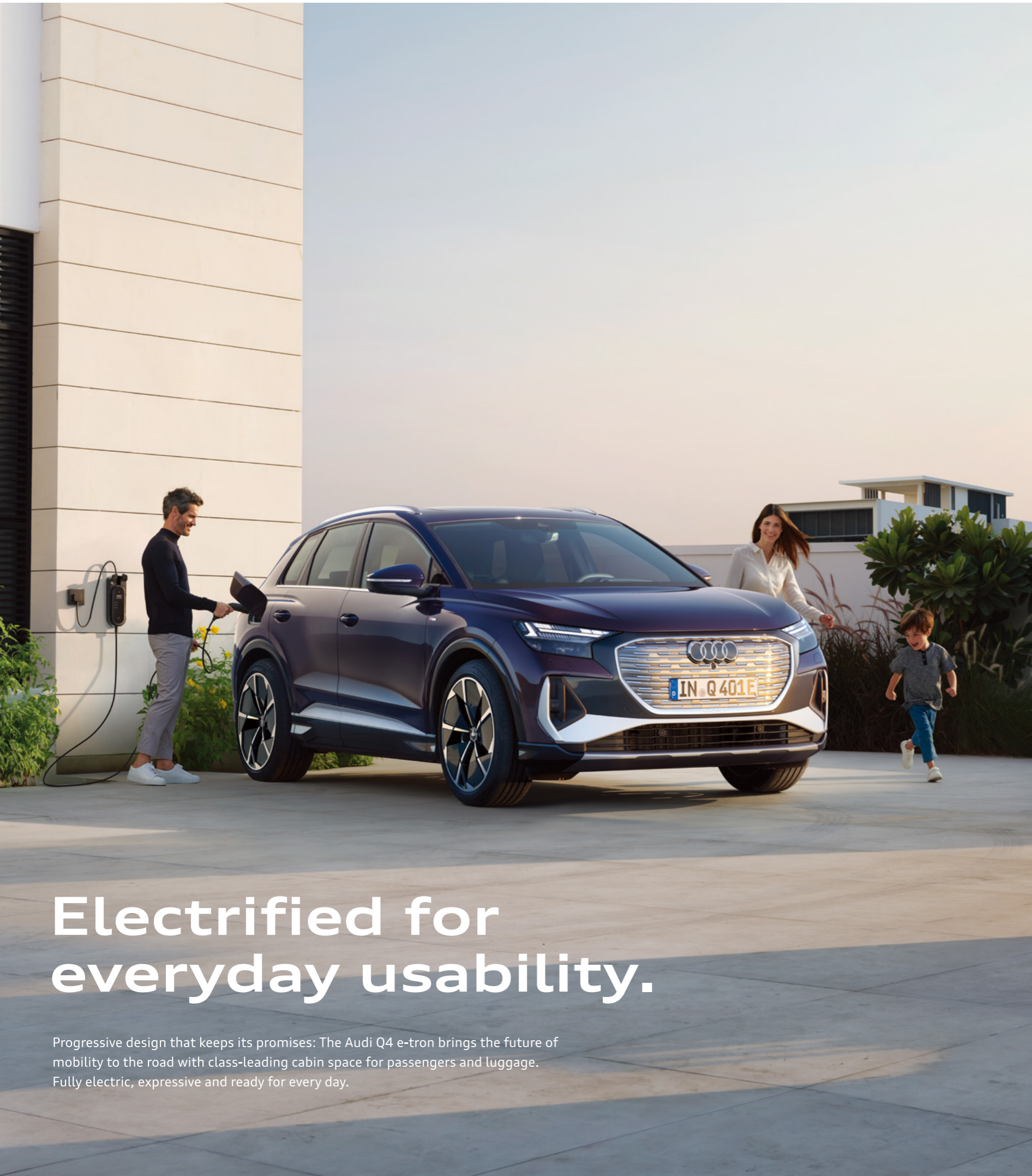

# Electrified for everyday usability.

Progressive design that keeps its promises: The Audi Q4 e-tron brings the future of mobility to the road with class-leading cabin space for passengers and luggage. Fully electric, expressive and ready for every day.



## Charging made simple.

With the mobile and flexible e-tron charging system compact, you can charge the vehicle easily and conveniently at home. Wherever there is an accessible power socket. For faster charging, it is also compatible with industrial power sockets.



## Fast and efficient charging.

Battery charged from 10% to 80% in 25 mins at maximum DC charging power of up to 175 kW, and capable to charge up to 115km range in just 10 mins.

Final equipment subject to specification sheet.  
For detailed information, please contact sales hotline 2291 0000.  
Overseas model is indicated, specification and feature may differ in Hong Kong.



# Fascinatingly futuristic.

The clear design of the Audi Q4 e-tron gives a characteristic form to the future of electric mobility.



## Class-leading wheelbase.

The wheelbase of the Audi Q4 e-tron is the longest among its segment, and the flat floor design creates spacious interior and legroom for passengers in rear to enjoy pleasant long journeys.



## Light reimaged.

A choice of 4 daytime running light signatures combined with dynamic light sequencing demonstrates the pioneering lighting technology, and makes an impressively progressive statement.



## Agile handling for urban driving.

The turning circle of the Audi Q4 e-tron is 10.2 meters, which is the shortest among its class and even less than the Audi A1 and Q3. It offers flexibility when parking and maneuvering in urban areas.

Final equipment subject to specification sheet.  
For detailed information, please contact sales hotline 2291 0000.  
Overseas model is indicated, specification and feature may differ in Hong Kong.



# Functional sportiness.

The progressive interior of the Audi Q4 e-tron is characterised by technological innovation, sportiness and functionality.

## More room for more.

As a real all-rounder and family car, the Audi Q4 e-tron offers a generous selection of storage solutions – providing a total volume of 24.8 litres including the glove compartment. The luggage compartment of the Audi Q4 e-tron can stow 520 litres of luggage. With the rear seats folded down, the volume goes up to 1,490 litres.

## Ambience in a new light.

This lighting package creates a unique atmosphere and lends the interior of the Audi Q4 e-tron a fascinating ambience with a feel-good factor. Precise contour lighting emphasises the instrument panel, the centre console and other prominent design structures.

## The future in your hands: Steering wheels with touch operation.

The upper spokes feature touch surfaces in black-panel look with backlit functional areas to indicate the active buttons. Slight protrusions separate these from one another, making them easier to use, and the buttons provide gentle haptic feedback when pressed.

Final equipment subject to specification sheet. For detailed information, please contact sales hotline 2291 0000. Overseas model is indicated, specification and feature may differ in Hong Kong.

# Q4 e-tron 45



## Alloy wheels

**Standard**  
(For Hong Kong Models)

**Optional<sup>^</sup>**

19"



19" Five-W-spoke aero wheel,  
2-tone graphite & high sheen

20"



20" Five-Y-spoke wheel,  
2-tone Graphite-Diamond

21"



21" Audi Sport wheels,  
Five-W-spoke, platinum grey

## S-line Sport+ package<sup>^</sup>



S-line exterior package with  
Black-styling elements



Double-spoke sports steering  
wheel with shift paddles,  
S emblem



S-line interior with front sports  
seats with S-embossing



Suspension system with  
damper control



SONOS premium sound system



Illuminated door sills with  
aluminium inserts and  
S-letting

# The Audi premium customised paint finishes

You don't get a second chance to make a first impression. Seize this one and choose your own personal exterior paint finish from the wide range of colours.

## Exterior paint

**Metallic**

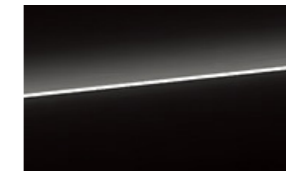

Mythos Black



Glacier White



Typhoon Grey



Floret Silver

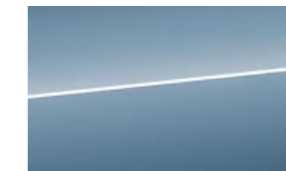

Geyser Blue



Navarra Blue

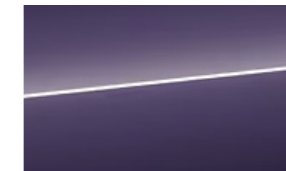

Aurora Violet

**Solid**



Pebble Grey (Exclusive for S-line Sport+ package)<sup>^</sup>

## Leather combination upholstery



<sup>^</sup>Optional equipment.  
Final equipment subject to specification sheet.  
For detailed information, please contact sales hotline 2291 0000.

|  |   |
|--|---|
| <b>Model</b>   | <b>Q4 e-tron 45</b>                                     |
| Engine type  | Lithium-ion high-voltage battery powered, full electric |
| Battery capacity   | 82 kWh (gross)  |
| Max. output  | 286 ps (210 kW)   |
| Max. torque  | 545 Nm  |
| <b>Power transmission</b>                                |   |
| Drive type   | Rear wheel drive  |
| <b>Weights / capacities</b>                              |   |
| Empty weight   | 2,125 kg  |
| Perm. Total weight                                       | 2,640 kg  |
| Permissible roof load limit / Support load               | 75/75 kg  |
| <b>Mileage</b>   |   |
| Top Speed  | 160 km / h  |
| Acceleration   | 0-100 km / h in 6.7 s                                   |
| <b>Consumption</b>                                       |   |
| Fuel type  | Electric  |
| <b>Consumption and emission values according to WLTP</b> |   |
| Combined   | 19.9-17.9 kWh / 100 km                                  |
| Combined CO <sub>2</sub> emissions                       | 0 g / km  |
| Electric range (combined)                                | 547 km  |

### Explanatory note

1. The power available in the individual driving situation depends on variable factors such as outside temperature, temperature, charging and conditioning status or physical aging of the high-voltage battery.
2. The charging time/charging capacity of the battery can vary depending on various factors such as the ambient and battery temperature, the use of other country-specific plugs, the use of the preconditioning function (e.g. remote-controlled climate control of the vehicle), the power availability at the charging station, state of charge and Battery aging vary. The charging power decreases as the state of charge increases. The loading losses are taken into account. HPC: High Power Charging with DC.
3. Unladen vehicle weight with driver (75 kg), determined according to the current version of Regulation (EU) 1230/2012. Optional equipment can increase the unladen weight and the drag coefficient of the vehicle, which reduces the possible payload and maximum speed accordingly.
4. Further information on the official fuel consumption and the official specific CO<sub>2</sub> emissions of new passenger cars can be found in the "Guide to fuel consumption, the CO<sub>2</sub>-Emissions and power consumption of new passenger cars" which is available at all sales outlets and at DAT Deutsche Automobil Treuhand GmbH, Hellmuth-Hirth-Str. 1, D-73760 Ostfildern or at [www.dat.de](http://www.dat.de) free of charge.

## Audi Q4 e-tron

Dimensions in mm

Dimensions at unladen vehicle weight

The values given are nominal values determined on the basis of data. They are based on the data available at the time of calculation and the defined equipment variant.

1) Shoulder Width 2) Elbow Width 3) Maximum headroom

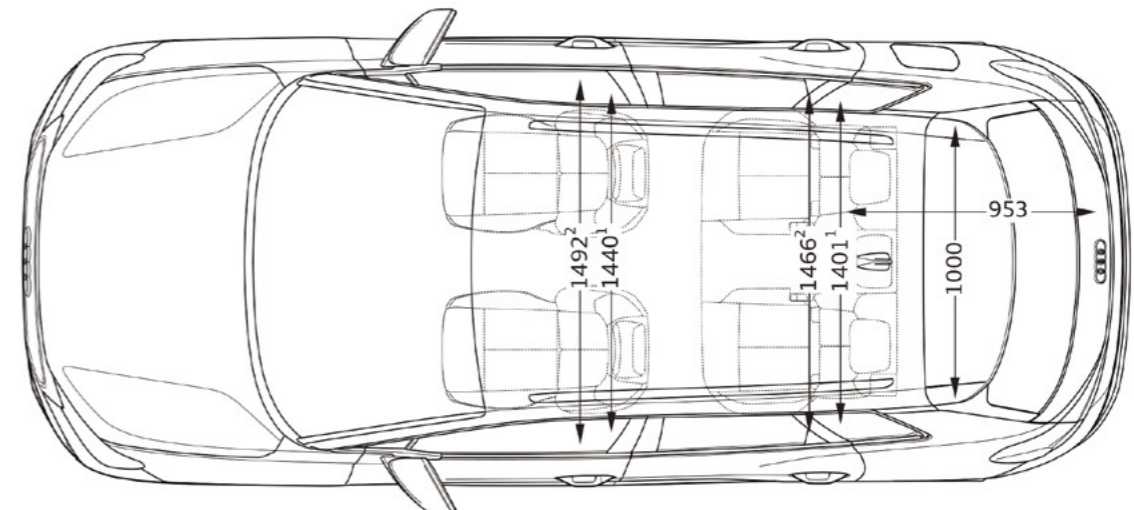
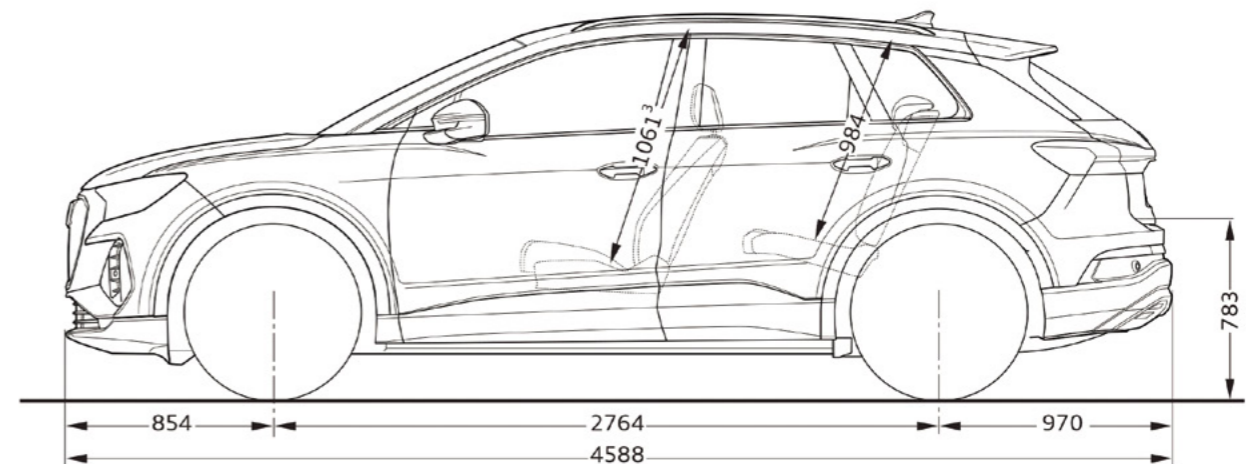
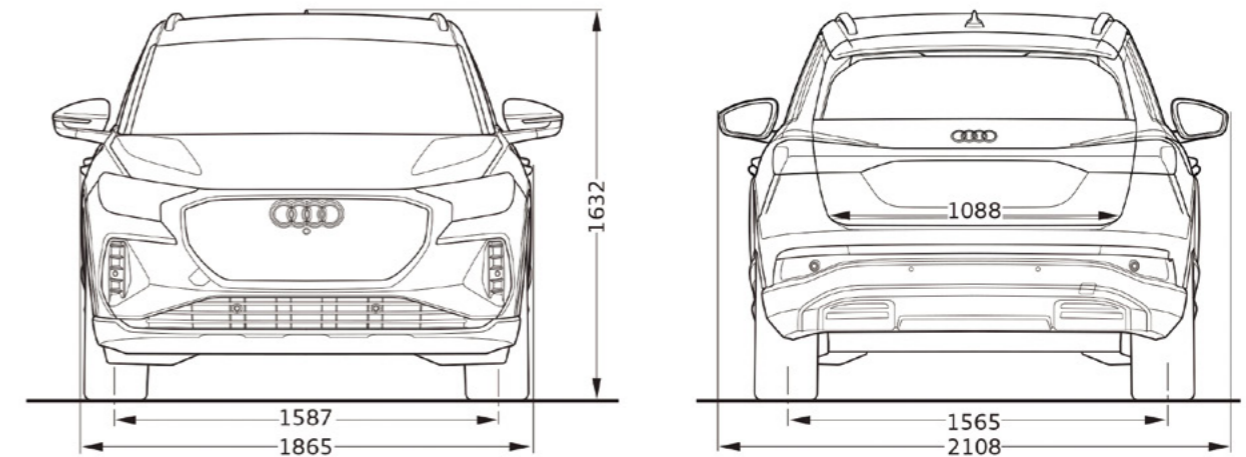



## 錦龍汽車集團奧迪銷售服務網絡

# Kam Lung Motor Group Audi Sales & Service Network

### 香港 Hong Kong

奧迪太古城旗艦陳列室  
Audi Taikoo Shing Flagship Showroom

奧迪九龍陳列室  
Audi Kowloon Showroom

奧迪荃灣售後服務中心  
Audi Service Centre Tsuen Wan

奧迪柴灣售後服務中心  
Audi Service Centre Chai Wan

### 澳門 Macau

奧迪澳門（澳門氹仔）  
Audi Macau (Taipa, MO)

### 深圳 Shenzhen

深圳錦龍（深圳南山）  
SZ Kam Lung (Nanshan, SZ)

深圳錦奧（深圳龍崗）  
SZ JinAo (Longgang, SZ)

深圳奧德（深圳羅湖）  
SZ AoDe (Luohu, SZ)

深圳德迪（深圳蛇口）  
SZ DeDi (Shekou, SZ)

### 廣州 Guangzhou

廣州錦龍（廣州天河）  
GZ Kam Lung (Tianhe, GZ)

廣州錦龍二沙島體驗中心（廣州二沙島）  
Audi Centre Ersha Island (Ersha Island, GZ)

廣州奧德（廣州天河）  
GZ AoDe (Tianhe, GZ)

廣州德迪（廣州南沙）  
GZ DeDi (Nansha, GZ)

肇慶錦龍（肇慶高要）  
ZQ Kam Lung (Gaoyao, GZ)

 [www.audi.com.hk](http://www.audi.com.hk)

 Audi Hong Kong

 audihk

 Audi Hong Kong

 Audi Hong Kong

查詢熱線 Sales Enquiry Hotline:

2291 0000

© 2023 Kam Lung Motors Limited. All rights reserved

\* 根據原廠保用條款和條件。

\*Warranty terms and conditions applied.

[www.kamlung.com](http://www.kamlung.com)